

STOP GLOBE VALVE ACID-PROOF TYPE ZKA100

CHARACTERISTIC:

Diameter	-	15 -200 mm;
Pressure	-	100 bar;
Temperature	-	up to 250°C for acids, bases and other aggressive media;
	-	up to 550°C for non-toxic media; (with PTFE sealing up to 200°C);
Medium	-	acids, liquors, water, steam and other non-toxic and non aggressive media, engine fuel and sea water

VERSIONS: type - body material / ends / disc and disc ring / others

Example: ZKA100 / --- / --- / ---

Example: ZKB100 / S / R / ---

Type - body material	Sign	Ends	Sign	Disc and disc ring	Sign	Drive type	Sign	Others	Sign
X6CrNi18-10 or GX5CrNi19-10	ZKA100	Standard - flanged	---	Standard	---	Hand wheel	---	-----	---
X2CrNiMo17-12-2 or GX5CrNiMo19-11-2	ZKB100	Butt weld ends	S	Throttle plug	R	AUMA drive	NA		
		Socket weld	SW	Throttle plug	RR	NWA drive	NW		
		Threaded	G	Throttle plug	Q	MODACT drive	NM		
				PTFE ring	P	Pneumatic drive	NP		
				NBR ring	N				

APPLICATION:

Stop globe valve is designed to open and stop the flow. The valve is not supposed to be used as regulating device. For regulation the version "R" with throttling plug should be applied.

DN 15 ÷ 40

"SW"

DN 50 ÷ 200

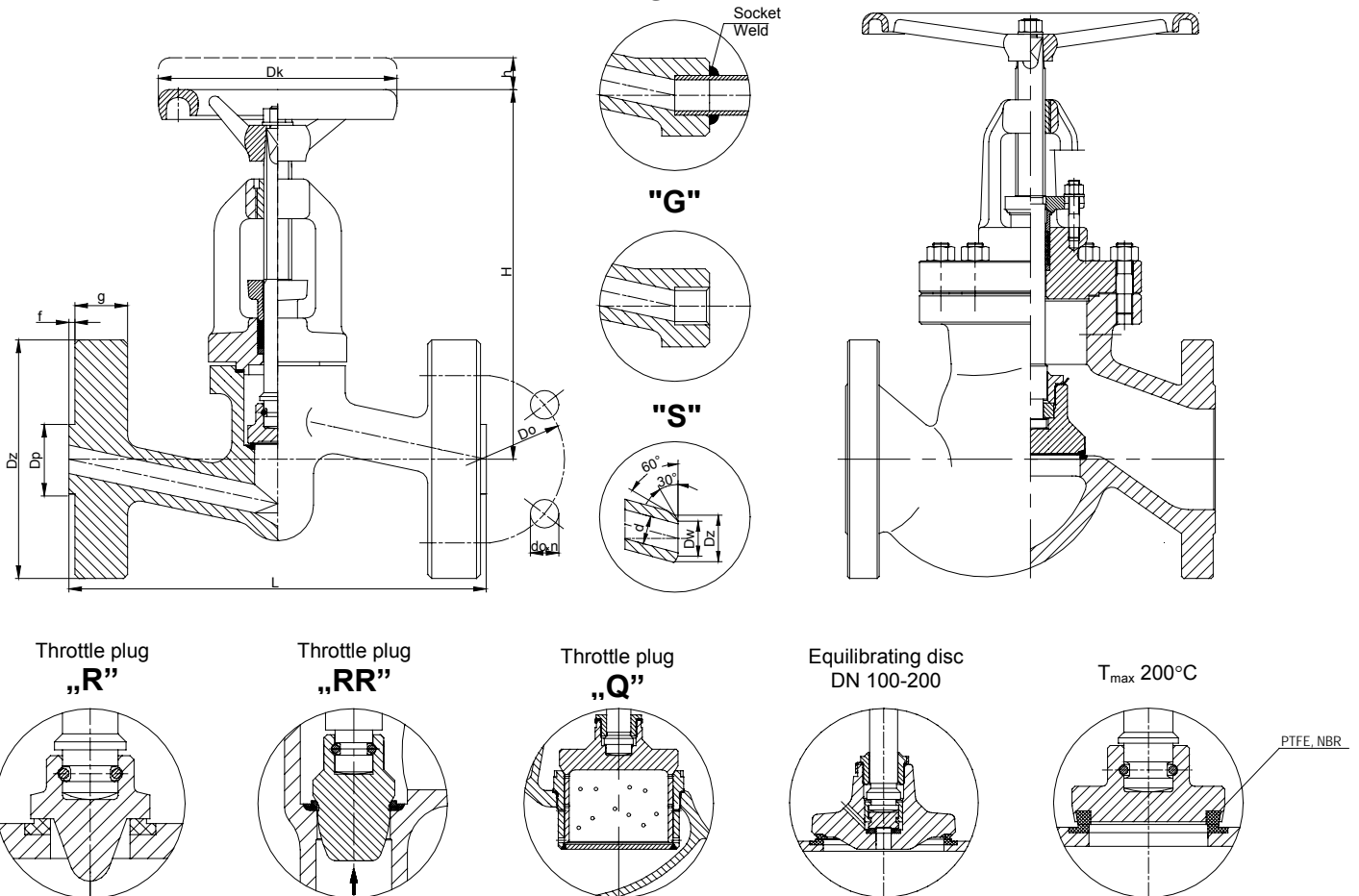

WK



FABRYKA ARMATURY PRZEMYSŁOWEJ

„WAKMET” spółka jawna

Kaczmarek, Krzywdziński, Wachowski, Wilczyński

Bodzanów 75 48-340 GŁUCHOŁAZY 1

tel. +48(077) 439-40-20, fax +48(077) 439-18-72

e-mail: wakmet@wakmet.com.pl

http: www.wakmet.com.pl

MATERIALS:

Version	ZKA100	ZKB100	ZKA100	ZKB100
Parts	DN 15 - 40		DN 50 - 200	
Body, bonnet	X6CrNiTi18-10 (1.4541)	X2CrNiMo17-12-2 (1.4404)	GX5CrNi19-10 (1.4308)	GX5CrNiMo19-11-2 (1.4408)
Disc	X6CrNiTi18-10 (1.4541)	X2CrNiMo17-12-2 (1.4404)	X6CrNiTi18-10 (1.4541)	X2CrNiMo17-12-2 (1.4404)
Stem	X6CrNiTi18-10 (1.4541)	X2CrNiMo17-12-2 (1.4404)	X6CrNiTi18-10 (1.4541)	X2CrNiMo17-12-2 (1.4404)
Gasket	Grafit + austenite			
Wheel	Cast iron			

Special materials on request; modifications reserved.

DIMENSIONS:

Standard - flanged														With butt weld ends			
DN	d	Dz	Dp	Do	do	n	L	g.	f	H	h	Dk	Weight	Dz	Dw	L	Weight
15	14	105	45	75	14	4	210	20	2	160	13	120	5,40	22	17	160	3,00
20	19	130	58	90	18	4	230	22	2	160	13	160	9,80	28	21,5	160	3,00
25	23	140	68	100	18	4	230	24	2	160	13	160	10,80	35	28,5	160	3,00
32	30	155	78	110	22	4	260	24	2	210	16	200	15,00	44	36	230	9,30
40	38	170	88	125	22	4	260	28	3	210	18	200	15,70	50	43	230	9,50
50	45	195	102	145	26	4	300	28	3	250	22	250	30,70	62	54	300	19,90
65	62	220	122	170	26	8	340	30	3	290	30	280	46,00	77	69	340	30,90
80	73	230	138	180	26	8	380	32	3	300	40	360	62,00	91	81	380	48,70
100	94	265	162	210	30	8	430	36	3	500	55	360	121,50	117	104	430	95,10
125	120	315	188	250	33	8	500	40	3	600	65	400	168,00	144	127	500	137,90
150	144	355	218	290	33	12	550	44	3	700	70	500	251,00	172	154	550	201,10
200	195	430	285	360	36	12	650	52	3	900	100	600	295,00	223	199,5	650	218,00

Dimensions in mm; modifications reserved.

TECHNICAL DATA:

Body material	Medium	PN	Maximal working pressure at working temperature															
			20°C	100°C	150°C	200°C	250°C	300°C	350°C	400°C	450°C	480°C	500°C	510°C	520°C	530°C	540°C	550°C
X6CrNiTi18-10 (1.4541)	aggressive media	100	100,0	99,0	93,3	88,5	84,2	-	-	-	-	-	-	-	-	-	-	
GX5CrNi19-10 (1.4308)		100	100,0	90,9	81,9	74,7	69,0	-	-	-	-	-	-	-	-	-	-	
X6CrNiTi18-10 (1.4541)	non aggressive media	100	100,0	99,0	93,3	88,5	84,2	79,5	76,6	74,2	72,6	71,5	70,9	70,0	69,5	68,7	68,0	67,6
GX5CrNi19-10 (1.4308)		100	100,0	88,1	76,2	67,9	59,5	55,9	52,4	48,8	45,2	41,6	38,1	-	-	-	-	
X2CrNiMo17-12-2 (1.4404)	Aggressive media	100	100,0	100,0	97,6	92,9	91,6	-	-	-	-	-	-	-	-	-	-	
GX5CrNiMo19-11-2 (1.4408)		100	100,0	80,9	72,6	64,3	59,5	-	-	-	-	-	-	-	-	-	-	
X2CrNiMo17-12-2 (1.4404)	Non Aggressive media	100	100,0	100,0	97,6	92,9	91,6	86,3	82,7	80,4	78,3	77,3	76,2	76,1	75,9	75,8	75,6	75,6
GX5CrNiMo19-11-2 (1.4408)		100	100,0	80,9	72,6	64,3	59,5	54,8	52,4	50,0	48,6	48,2	47,9	-	-	-	-	

MOUNTING AND OPERATING:

The valve can only be mounted and operated by skilled, properly trained and qualified personnel. Incorrect assembly or operation of the valve may have substantial impact on the entire system such as fluid leakage, reduction in system's function etc.

Before a valve is installed the pipeline must be clean from any mechanical impurities. The compatibility of critical parameters of the flow must be checked with the parameters of the valve. Stop globe valve can be mounted to a pipe-line in any position. The direction of flow should only comply with the arrow marked on the body. The valve should be operated strictly with its assign. In order to provide valve's reliability the following suggestions must be observed:

- medium flowing through the valve is supposed to be clean out of any mechanical impurities;
- the valve must be protected from any mechanical damages during its work;
- nominal parameters marked on the valve must be observed.