

ASD Desuperheater

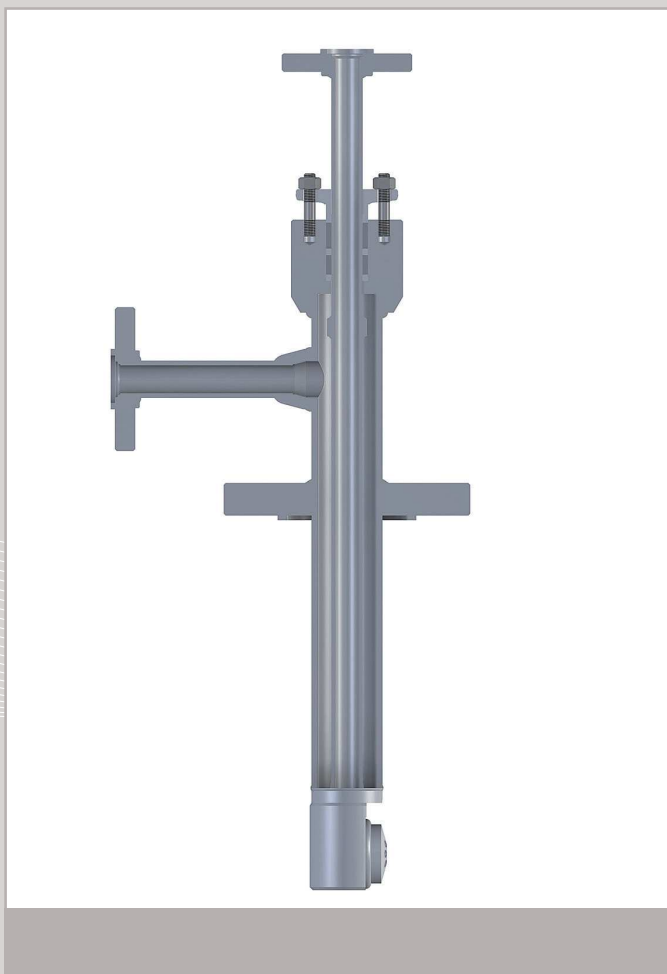

Application

ASD desuperheater has a steam atomized design. It is suitable for the installations, where precise temperature control is needed, as well as precise tuning and adequate spray of the cooling medium if low velocity of the steam in the pipeline happens.

Description

ASD desuperheater incorporates the use of high-pressure steam for rapid and complete atomization of the spraywater. The atomization undergoes in steam assisted nozzle placed in desuperheater's head. The atomizing steam (supplied through upper connection pipe), usually of supercritical velocity, is used to atomize the water into the very small droplets. These smaller droplets allow for faster conversion to steam and permit the water to remain suspended in a low steam velocity flow. ASD handles applications requiring very high load changes (rangeability up to 60:1).

Fed with cooling water externally (through separate side connection pipe) maintenance-free ASD desuperheater has not any moving or quick wearing parts. It is assembled to the flanged connection pipe of the steam pipeline.

Technical data

	steam pipeline	pipeline of injected water	pipeline of the atomizing steam
Nominal diameter	DN200÷DN600	DN15÷DN50	DN15÷DN50
Nominal pressure	PN10÷PN400	PN25÷PN400	PN25÷PN400
Connections	bolted flanges	bolted flanges; welding ready	bolted flanges; welding ready
Flow coefficient Kvs	≥ 1 m ³ /h		
Body	1.0460 (P250GH)	1.7335 (13CrMo4-5)	1.7715 (14MoV6-3)
	1.5415 (16Mo3)	1.7380 (10CrMo9-10)	1.4903 (X10CrMoVNb9-1)
Injection nozzle	1.4541(X6CrNiTi18-10) + stellite		
Rangeability	60:1		
Orientation of water's inlet connection pipe towards direction of steam's flow	0°; 90°; 180°; 270°; 360°		

INTEC

Industrial Automatics Enterprise INTEC Ltd. Co.
ul. Bacciarellego 54, 51-649 Wrocław, Poland
tel./fax: + 48 71 348 18 18, e-mail: biuro@intec.com.pl
www.intec.com.pl

WK

WAKMET Industrial Valves Factory Ultd.
Bodzanów 75, 48-340 Głucholazy 1, Poland
tel./fax: + 48 77 439 40 20, e-mail: wakmet@wakmet.com.pl
www.wakmet.com.pl